

## TA9000-LM-2030

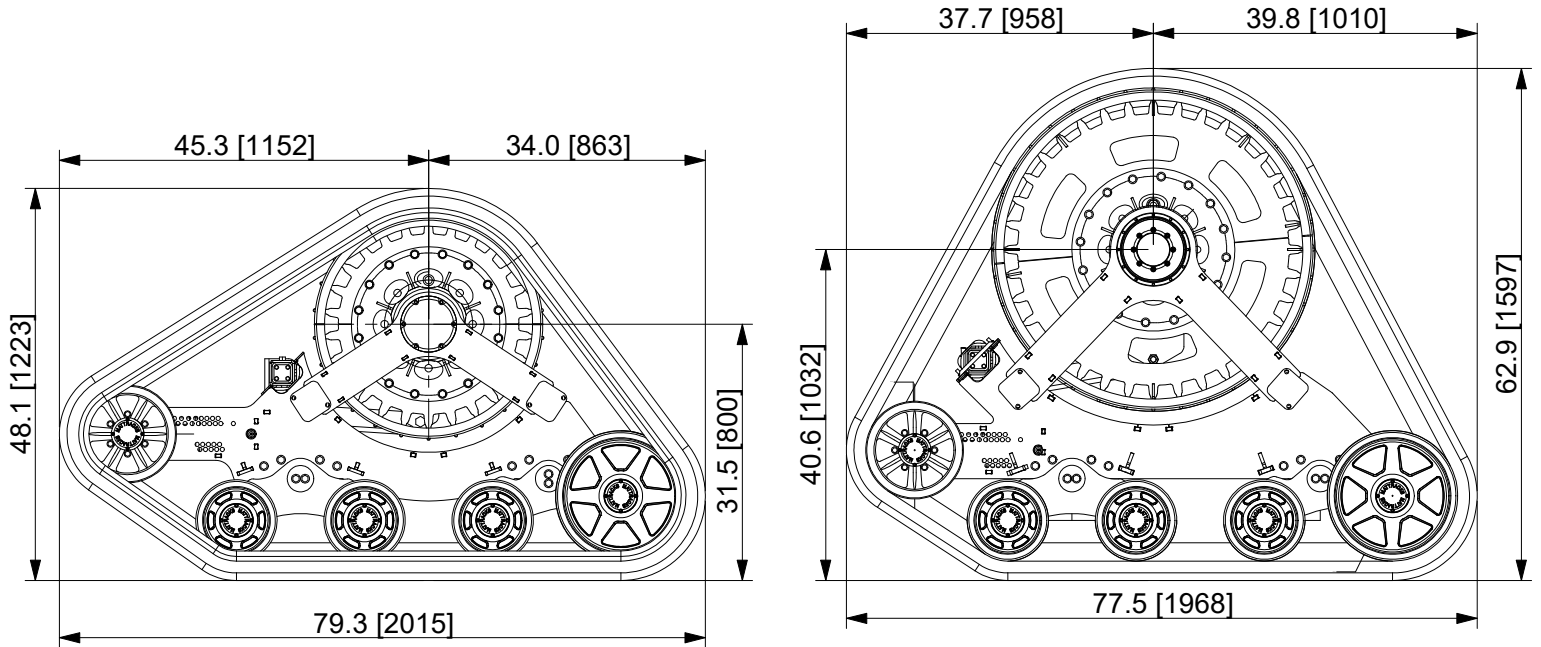

<b>EXCLUSIVE ANTI-TORQUE SYSTEM</b>	Rubber Torsion
<b>FRAME CONSTRUCTION</b>	HSLA Steel
<b>RECOMMENDED MAX SPEED</b>	15 mph
<b>FRAME CONSTRUCTION</b>	Steel
<b>INTERNAL SUSPENSION</b>	Concentric Pivot, Rocker Arm
<b>TRACK TREAD WIDTH</b>	Front: 20" / Rear: 30"
<b>TRACK TREAD STYLE</b>	All-Terrain, Self-Cleaning
<b>TRACK MATERIAL</b>	Rubber with Internal Composite Rods/Cord
<b>RECOMMENDED OPERATING TEMP</b>	(Ambient) -40° to +130°
<b>GROUND CONTACT LENGTH</b>	Front: (Hard Surface) 47.2" / (Soft Surface) 79.3" Rear: (Hard Surface) 47.2" / (Soft Surface) 77.5"
<b>GROUND CONTACT SURFACE AREA</b>	Front: 3,055 in <sup>2</sup> min / 3,965 in <sup>2</sup> max Rear: 3,684 in <sup>2</sup> min / 4,650 in <sup>2</sup> max
<b>SPROCKET DIAMETER</b>	Front: 29.0" / Rear: 40.1"
<b>WHEELS TYPE</b>	10"/13"/16" x 2.5"
<b>ROAD WHEEL COUNT</b>	11, 3 rows
<b>WHEEL MATERIAL</b>	UMHW / Rubber, Alum / Rubber
<b>PAINT COLOR</b>	Yellow (Standard, other colors available)

\*DEPENDING ON VEHICLE, CARGO, AND ACCESSORIES \*\*SOME VEHICLES MAY REQUIRE SLIGHT ALTERATIONS  
ALL SPECIFICATIONS ARE APPROXIMATE AND WE RESERVE THE RIGHT TO MAKE CHANGES OR MODIFICATIONS WITHOUT NOTIFICATION