

## TA9000-LM-1010

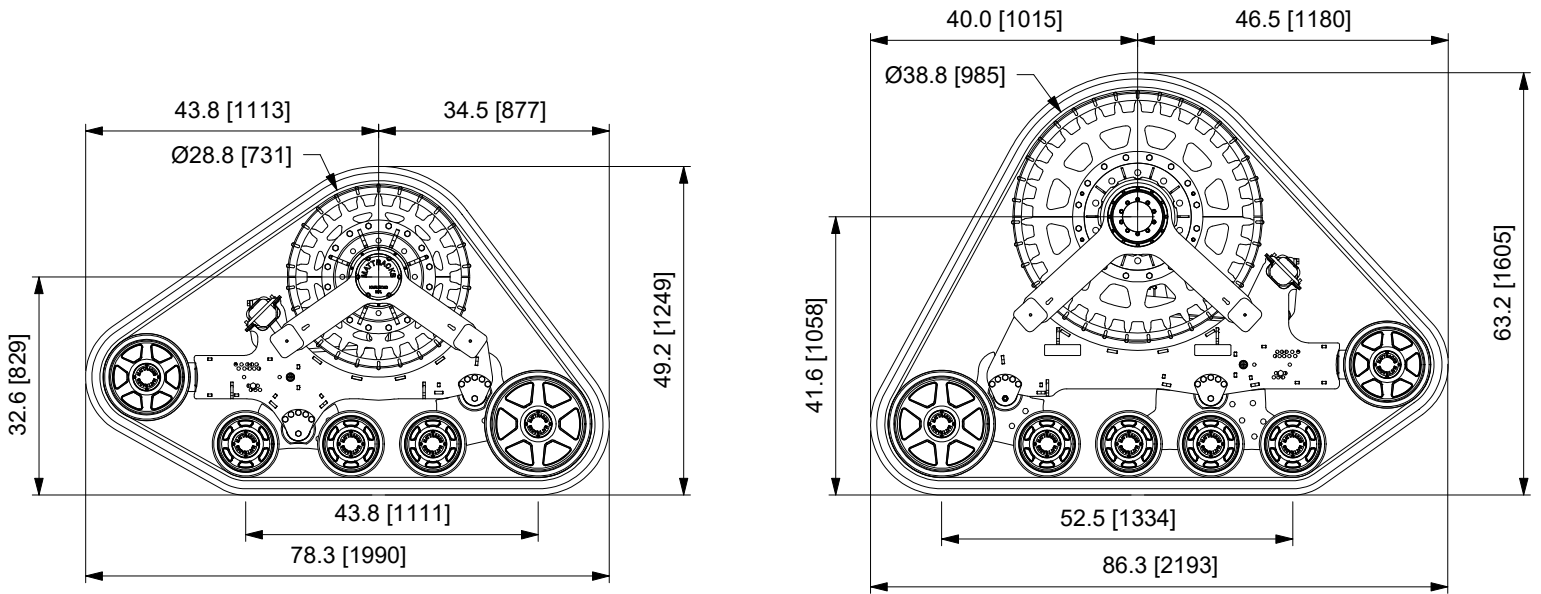

<b>EXCLUSIVE ANTI-TORQUE SYSTEM</b>	Rubber Torsion
<b>FRAME CONSTRUCTION</b>	HSLA Steel
<b>RECOMMENDED MAX SPEED</b>	15 mph
<b>FRAME CONSTRUCTION</b>	Steel
<b>INTERNAL SUSPENSION</b>	Concentric Pivot, Rocker Arm
<b>TRACK TREAD WIDTH</b>	9.6"
<b>TRACK TREAD STYLE</b>	All-Terrain, Self-Cleaning
<b>TRACK MATERIAL</b>	Rubber with Internal Composite Rods/Cord
<b>RECOMMENDED OPERATING TEMP</b>	(Ambient) -40° to +130°
<b>GROUND CONTACT LENGTH</b>	Front: (Hard Surface) 43.8" / (Soft Surface) 78.3" Rear: (Hard Surface) 52.5" / (Soft Surface) 86.3"
<b>GROUND CONTACT SURFACE AREA</b>	Front: 420.48 in <sup>2</sup> min / 751.68 in <sup>2</sup> max Rear: 504 in <sup>2</sup> min / 828.48 in <sup>2</sup> max
<b>SPROCKET DIAMETER</b>	Front: 28.8" / Rear: 38.8"
<b>WHEELS TYPE</b>	10"/13"/16" x 2.5"
<b>ROAD WHEEL COUNT</b>	Front: 8, 2 rows / Rear: 10, 2 rows
<b>WHEEL MATERIAL</b>	UMHW / Rubber, Alum / Rubber
<b>PAINT COLOR</b>	Yellow (Standard, other colors available)

ALL SPECS ARE PER CORNER

\*DEPENDENT ON VEHICLE, CARGO, AND ACCESSORIES \*\*SOME VEHICLES MAY REQUIRE SLIGHT ALTERATIONS  
ALL SPECIFICATIONS ARE APPROXIMATE AND WE RESERVE THE RIGHT TO MAKE CHANGES OR MODIFICATIONS WITHOUT NOTIFICATION